

**HSK-A63**

**Rapid feeds 75 m/min**

**Pallet dimensions 400x500**



Tool changing time	1 s
Number of tools HSK-A63	34/80
Tool regeneration + washing + tool check	5 s
Spindle speed	16.000/20.000//30.000 rpm
Continuous rotary table	4 / 5 / 6 Axes
Linear axes measuring system with pressurized optical scales	



# CONCEPT 2g 4/5/6 Axes

## TECHNICAL FEATURES

### WORKING AREA

Longitudinal X axis	mm	610
Vertical Y axis	mm	650
Transversal Z axis	mm	700
Rapid feeds	mm/min	75.000
Axes thrust	daN	900

### SPINDLE GROUP

#### Spindle type 16.000 rpm HSK-A63 DIN 69893-45 HV (base)/75 HV (optional)

Rotation speed	rpm	16.000
Continuous power (S1) /Power max (S6)	kW	40/50
Continuous torque (S1)/Tourque max (S6)	Nm	63/80 - (83/110)
Front bearing diameter	mm	70
Tool balance control		

#### Spindle type 20.000 rpm HSK-A63 DIN 69893-45 HV (opzionale)

Rotation speed	rpm	20.000
Continuous power (S1)	kW	25/33
Continuous torque /max torque	Nm	53/69
Front bearing diameter	mm	70
Variable pre-loading bearings		
Tool balance control		

#### Versione 30.000 rpm HSK-A63 DIN 69893-75 (opzionale)

Rotation speed	rpm	30.000
Continuous power (S1)	kW	60/68
Continuous torque (S1)	Nm	43/48
Front bearing diameter	mm	70
Tool balance control		

### TOOL CHANGER

Type	Wheel	
Tool magazine capacity	n.	34 (62)
Optional tool magazine capacity	n.	82
Max tool weight HSK A63	kg	8
Chip to chip tool changing time	s	4,7

### PALLET CHANGER

Pallet changing time	s	8
Number of pallet		2
Dimensione pallet	mm	400x500
Overall rotating diameter (4 and 5 axes)	mm	700
Max. load for pallet (4 and 5 axes)	kg	300

### CONTINUOUS ROTATING TABLE

Positions		3.600.000
Speed rotation	rpm	100

### CHIPS CONVEYOR

#### 5/6 Machine

### CONTINUOUS TILTING GROUP

Tilting angle		-90° +35°
Fixture overall rotation diameter	mm	600
B axis positions		3.600.000
B axis speed	rpm	100
A axis positions		1.250.000
A axis speed	rpm	50

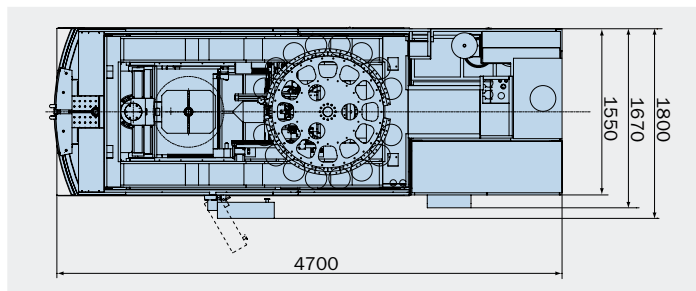

### CONCEPT 4 AXES

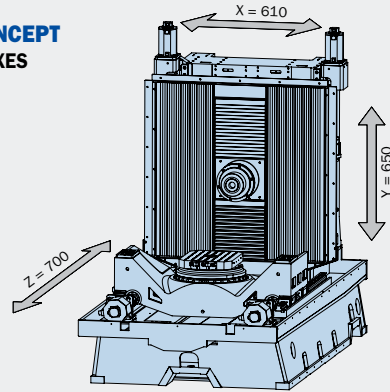

### CONCEPT 5 AXES

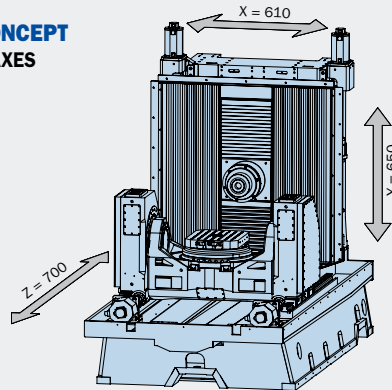

### CONCEPT 6 AXES

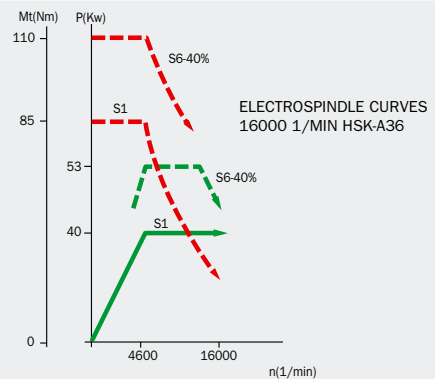
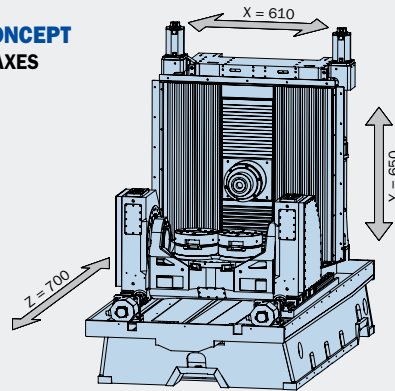

## MACHINING CENTERS MANUFACTURING

### MCM Spa

I-29020 Vigolzone (PC)  
Viale F. e G. Celaschi, 19  
Tel. ++39 0523 879901  
Fax ++39 0523 879130  
E-mail: divcomm@mcmspa.it  
http: www.mcmspa.it

### MCM FRANCE Sarl

F-91600 Savigny sur Orge  
6 Av. du Garigliano  
Tel. 01-69-21-21-00  
Fax 01-69-24-10-34  
E-mail: mcm@mcm-france.com

### MCM VERTRIEBS GmbH DEUTSCHLAND

D-65189 Wiesbaden Humboldtstraße, 13  
Tel. 0611-372747  
Fax 0611-372745  
E-mail: rebecca@t-online.de

### MCM CANADA

2311- 29th Ave. LAVAL WEST, QC  
H7R 3L4 CANADA  
Phone (450) 627 1414  
Fax (450) 627 7336  
E-mail: astefanoni@sympatico.ca

### MCM USA Inc.

34525 Melinz Parkway, Suite 208-C  
Eastlake, OH 44095 - U.S.A.  
Phone (440) 9181415  
Fax (440) 9180776  
Toll free 877 MCM 5999