

**HSK-A100**

**Rapid feeds 40 m/min.**

**Pallet dimensions**

**1,000x1,000/1,000x1,250**



Tool changing time	2 s
Number of tools	95-999
Tool regeneration+washing+tool check	10 s
Spindle speed	14,000/8,000/6,000 rpm
Continuous rotary table	
Linear axes measuring system with pressurized optical scales	



# ACTION 2600

## TECHNICAL FEATURES

### WORKING AREA

Longitudinal X axis	mm	2,600
Vertical Y axis	mm	1,600
Transversal Z axis	mm	1,700
Rapid feeds	m/min	40
Axes thrust	daN	3,500
Spindle tip-Y pallet distance	mm	75
Spindle tip-Z pallet distance	mm	130
Linear axes measuring system		pressurized Heidenhain optical scales
Rotating axes measuring system		pressurized Heidenhain encoders
AC axes servomotor drive with digital adjustment		

### POSITIONING PRECISION IN ACCORDANCE WITH VDI/DGQ 3441 SPECIFICATIONS

#### Linear axes (XYZ)

Positioning precision (Pa)	µm	8
Repeatability precision (Ps Med)	µm	4

#### Rotating axes (B)

Positioning precision (Pa)	arcsec	8
Repeatability precision (Ps med)	arcsec	4

### SPINDLE TYPE HSK-A100

Tool taper (DIN69893-1)	type	HSK-A100
Rotating speed	rpm	14,000/8,000/6,000
Power	kW	65/25/75
Max torque	Nm	400/600/1,000
Front bearing diameter	mm	110/130/130

### TOOL CHANGE

Standard features		
Wheel/rack type tool magazine capacity	n.	95-999
Max. tool length	mm	600
Max tool weight	kg	25
Chip to chip tool changing time	s	10
Max. tool diameter	mm	300x400
Adjacent tools max. diameter	mm	100

### PALLET CHANGER

Pallet changing time	s	20
Number of pallets	n.	2
Pallet dimensions	mm	1,000x1,000/1,000x1,200
Overall rotating diameter	mm	2,700
Max. load for pallet	kg	3,000

### CONTINUOUS ROTARY TABLE

Positions	n.	3,600,000
Speed rotation	rpm	8

### CHIPS CONVEYOR

Scraper type

### COOLANT SYSTEM

1,500 liters tank with self-cleaning filter

### TOTAL WEIGHT (Two pallets version)

kg 36,500

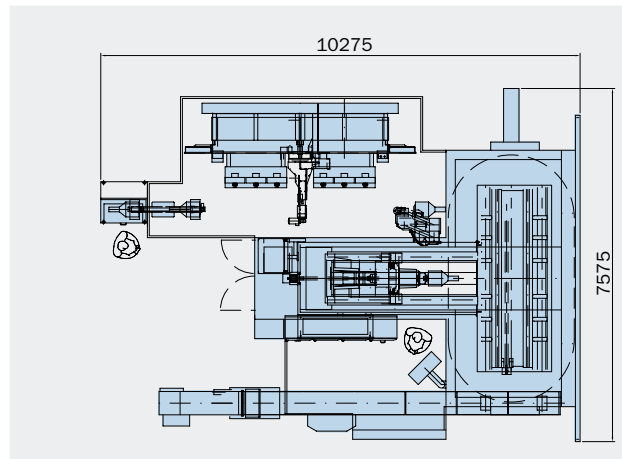
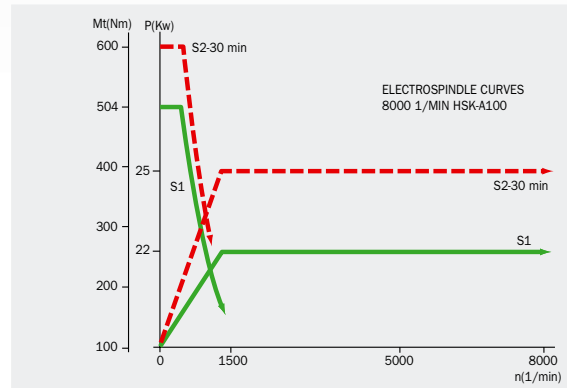
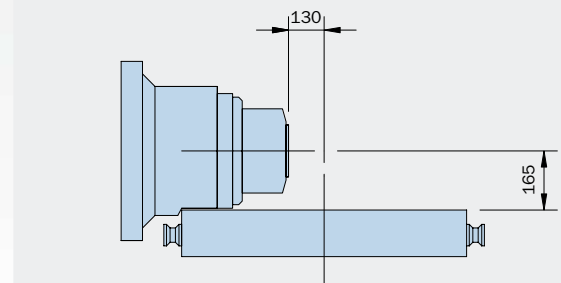
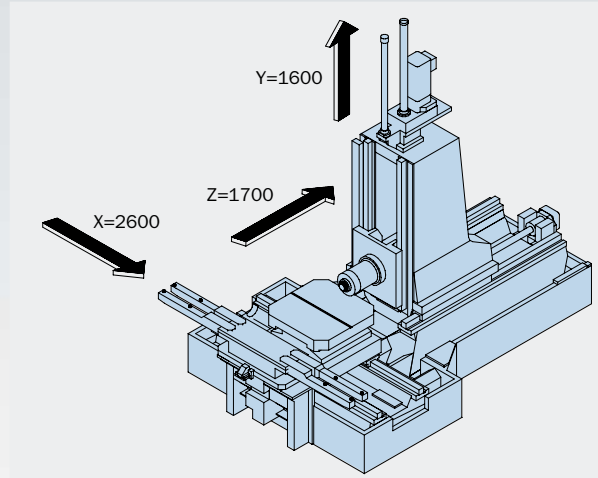

## MACHINING CENTERS MANUFACTURING

### MCM Spa

I-29020 Vigolzone (PC)  
Viale F. e G. Celaschi, 19  
Tel. ++39 0523 879901  
Fax ++39 0523 879130  
E-mail: divcomm@mcmspa.it  
http: www.mcmspa.it

### MCM FRANCE Sarl

F-91600 Savigny sur Orge  
6 Av. du Garigliano  
Tel. 01-69-21-21-00  
Fax 01-69-24-10-34  
E-mail: mcm@mcm-france.com

### MCM VERTRIEBS GmbH DEUTSCHLAND

D-65189 Wiesbaden Humboldtstraße, 13  
Tel. 0611-372747  
Fax 0611-372745  
E-mail: rebecchi@t-online.de

### MCM CANADA

2311- 29th Ave. LAVAL WEST, QC  
H7R 3L4 CANADA  
Phone (450) 627 1414  
Fax (450) 627 7336  
E-mail: astefanoni@sympatico.ca

### MCM USA Inc.

34525 Melinz Parkway, Suite 208-C  
Eastlake, OH 44095 - U.S.A.  
Phone (440) 9181415  
Fax (440) 9180776  
Toll free 877 MCM 5999