

UNIVERSAL HEAD TILTING TABLE

A-C axes 22,000 degrees/min.

HSK-A80 / HSK-A63

Linear axes rapid feeds 70 m/min.

Pallet dimensions 3,000x2,000

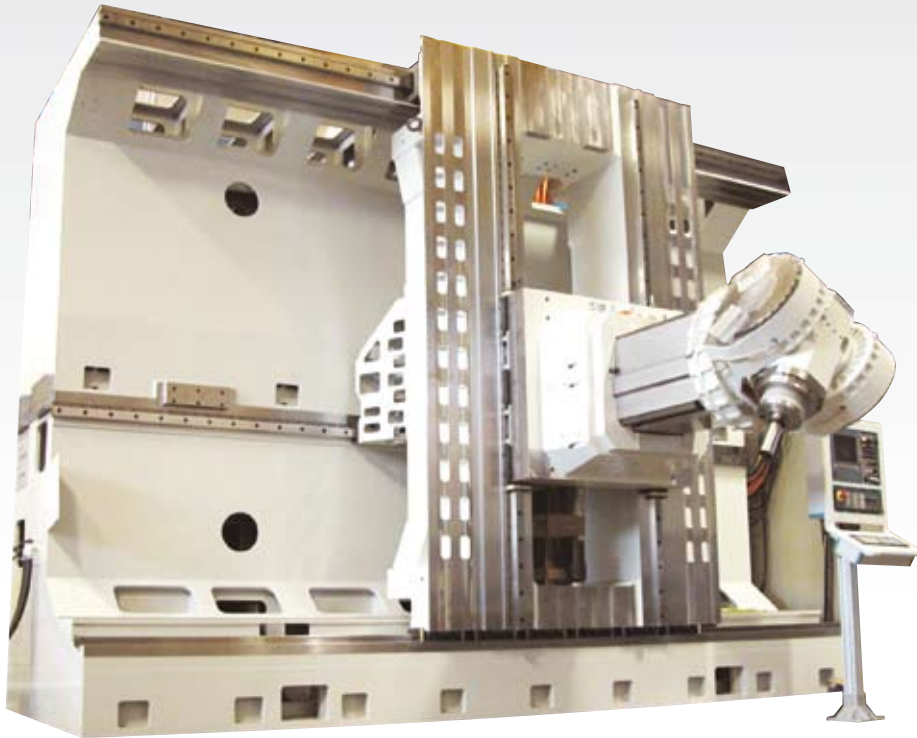

Tool changing time	2 s
Number of tools HSK-A100	148 -999
Spindle speed	20,000 rpm
Spindle power	75 kW
Spindle torque	200 Nm
Gantry control on all machine axes	
Linear axes measuring system with pressurized optical scales	



JETFIVE/L UNIVERSAL HEAD TILTING TABLE

TECHNICAL FEATURES

WORKING AREA

Longitudinal X axis	mm	3,000/7,000/11,000/15,000
Vertical Y axis	mm	2,000
Transversal Z axis	mm	600
Transversal table W axis	mm	800
Axes thrust	daN	4,000
Rapid feeds	m/min	70
Linear axes measuring system		pressurized Heidenhain optical scales
Rotating axes measuring system		pressurized Heidehain encoders
AC axes servomotor drive with digital adjustment		

SPINDLE

HSK-A80 / HSK-A63	rpm	20,000
Power	kW	75
Front bearing diameter	mm	100
A axis tilting angle	degrees	200
C axis tilting angle	degrees	360
Max torque	Nm	200

TOOL CHANGE

Standard features		
Rack type tool magazine capacity	n.	148 - 999
Max. tool length	mm	600
Max tool weight	kg	25
Chip to chip tool changing time	s	12
Max. tool diameter	mm	300
Adjacent tools max. diameter	mm	100

TILTING TABLE

Positions	n.	2
Pallet dimensions	mm	3,000x2,000/6,000x2,000
Max. load on pallet	kg	5,000

CHIPS CONVEYOR

Scraper type

COOLANT SYSTEM

1,500 liters tank with self-cleaning filter

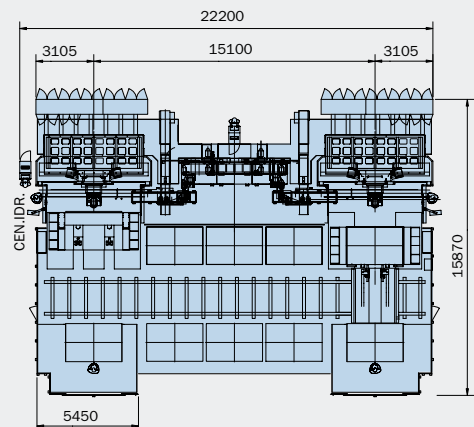
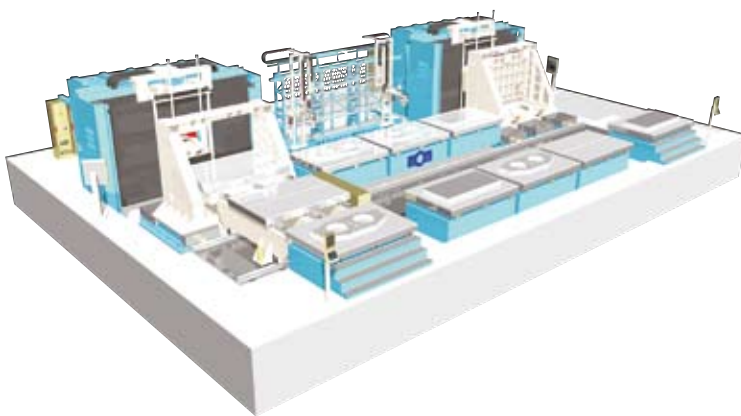
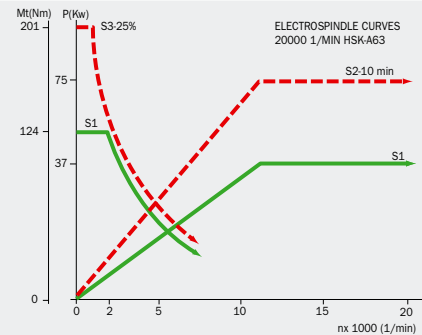
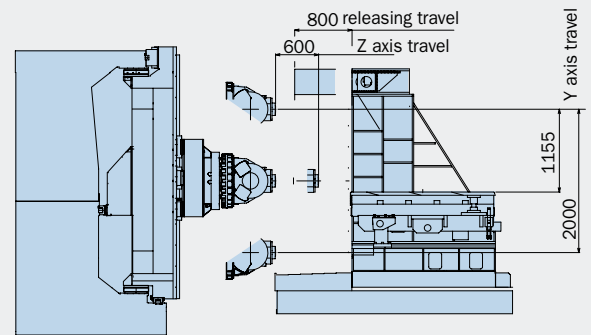
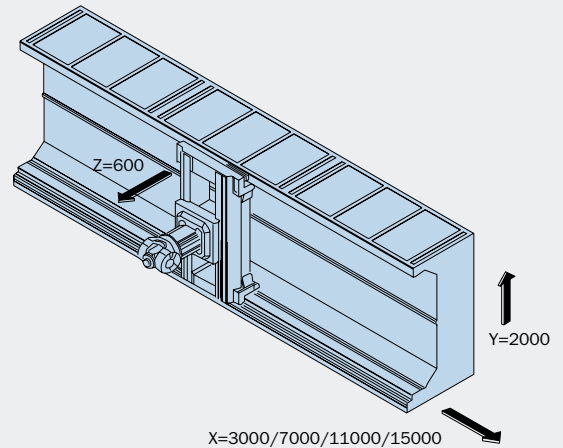

MACHINING CENTERS MANUFACTURING

MCM Spa

I-29020 VIGOLZONE (PC)
Viale F. e G. Celaschi, 19
Tel. ++39 0523 879901
Fax ++39 0523 879130
E-mail: divcomm@mcmspa.it
www.mcmspa.it

MCM FRANCE Sarl

F-91600 Savigny sur Orge
6 Av. du Garigliano
Tel. 01-69-21-21-00
Fax 01-69-24-10-34
E-mail: mcm@mcm-france.com

MCM VERTRIEBS GmbH

DEUTSCHLAND
D-65189 Wiesbaden Humboldtstraße, 13
Tel. 0611-372747
Fax 0611-372745
E-mail: rebecchi@t-online.de

MCM Spa

2311- 29th Ave. LAVAL WEST, QC
H7R 3L4 CANADA
Phone (450) 627 1414
Fax (450) 627 7336
E-mail: astefanoni@sympatico.ca

MCM USA Inc.

34525 Melinz Parkway, Suite 208-C
Eastlake, OH 44095-U.S.A.
Phone (440) 9181415
Fax (440) 9180776
Toll free 877 MCM 5999