

HORIZONTAL HEAD / TILTING HEAD

HSK-A100 Electrospindle 1000 Nm

Rapid feeds 40 m/min.

Pallet dimensions 1,250x1,250

TILTING head

A axis 12,000 degrees/min.



Tool changing time

2 s

Number of tools HSK-A100

148-999

Spindle speed

14,000/8,000/6,000 rpm

Spindle power

65/25/75 kW

Spindle torque

400/600/1,000 Nm

Gantry control on all machine axes

Linear axes measuring system with pressurized optical scales



JETFIVE/L

HORIZONTAL HEAD TILTING HEAD

TECHNICAL FEATURES

WORKING AREA

Longitudinal X axis	mm	3,000
Vertical Y axis	mm	2,000
Vert. Y axis with tilting head in vert. posit.	mm	1,700
Transversal Z axis	mm	2,000
Axes thrust	daN	4,000
Rapid feeds	m/min	40
Linear axes measuring system	pressurized Heidenhain optical scales	
Rotating axes measuring system	pressurized Heidenhain encoders	
AC axes servomotor drive with digital adjustment		

GANTRY TYPE TILTING SPINDLE HEAD

Tilting angle/Positions	degrees/n.	175/1,750,000
Tilting angle compared to horiz. position	degrees	+80/-95
Clamping torque	Nm	10,000

POSITIONING PRECISION IN ACCORDANCE WITH VDI/DGQ 3441 SPECIFICATIONS

Linear axes (XYZ)

Positioning precision (Pa)	µm	10
Repeatability precision (Ps Med)	µm	5

Rotating axes (B)

Positioning precision (Pa)	arcsec	6
Repeatability precision (Ps med)	arcsec	4

SPINDLE TYPE HSK-100

Tool taper (DIN69893-1)	type	HSK-A100
Rotating speed	rpm	14,000/8,000/6,000
Power	kW	65/25/75
Max torque	Nm	400/600/1,000
Front bearing diameter	mm	110/130/130

TOOL CHANGE

Standard features

Wheel/rack type tool magazine capacity	n.	148-999
Max. tool length	mm	600
Max tool weight	kg	25
Chip to chip tool changing time	s	12
Max. tool diameter	mm	300
Adjacent tools max. diameter	mm	100

CONTINUOUS ROTARY TABLE

Positions	mm	3,600,000
Speed rotation	rpm	8

CHIPS CONVEYOR

Scraper type

COOLANT SYSTEM

1,500 liters tank with self-cleaning filter

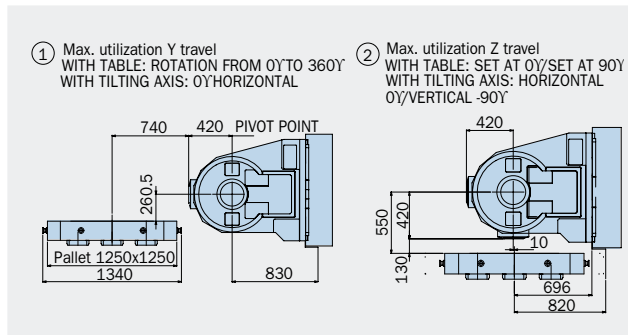
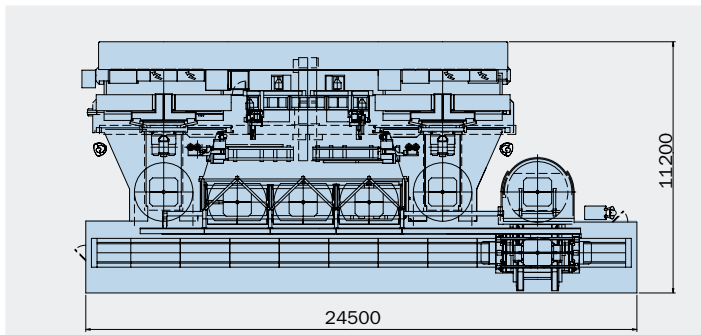
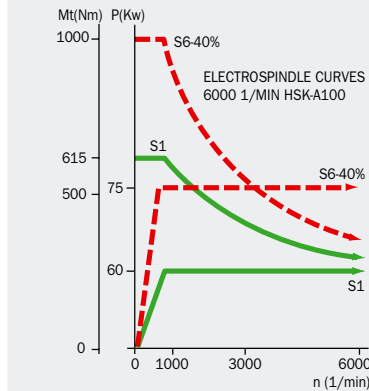
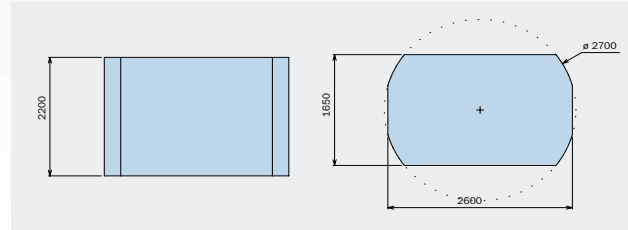
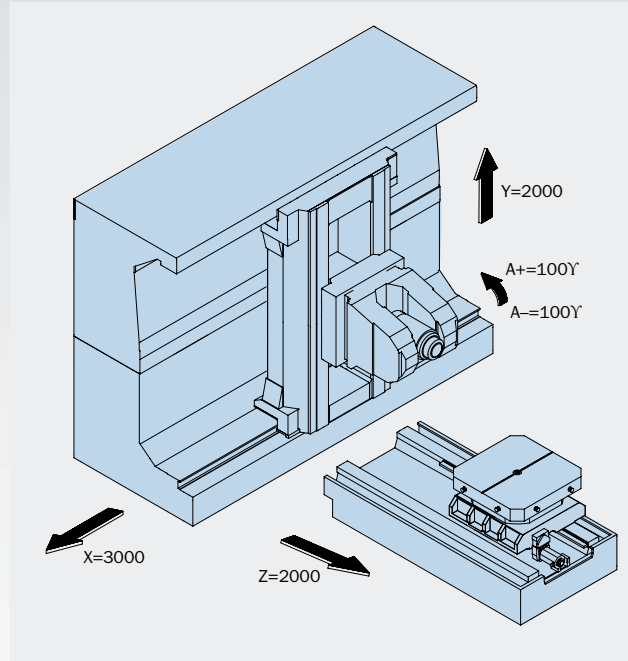

MACHINING CENTERS MANUFACTURING

MCM Spa

I-29020 Vigolzone (PC)
Viale F. e G. Celaschi, 19
Tel. ++39 0523 879901
Fax ++39 0523 879130
E-mail: divcomm@mcmspa.it
http: www.mcmspa.it

MCM FRANCE Sarl

F-91600 Savigny sur Orge
6 Av. du Garigliano
Tel. 01-69-21-21-00
Fax 01-69-24-10-34
E-mail: mcm@mcm-france.com

MCM VERTRIEBS GmbH DEUTSCHLAND

D-65189 Wiesbaden Humboldtstraße, 13
Tel. 0611-372747
Fax 0611-372745
E-mail: rebecca@t-online.de

MCM CANADA

2311- 29th Ave. LAVAL WEST, QC
H7R 3L4 CANADA
Phone (450) 627 1414
Fax (450) 627 7336
E-mail: astefanoni@sympatico.ca

MCM USA Inc.

34525 Melinz Parkway, Suite 208-C
Eastlake, OH 44095 - U.S.A.
Phone (440) 9181415
Fax (440) 9180776
Toll free 877 MCM 5999