

CAPTO C6
Rapidi 75 m/min
Dimensione pallet Ø 400

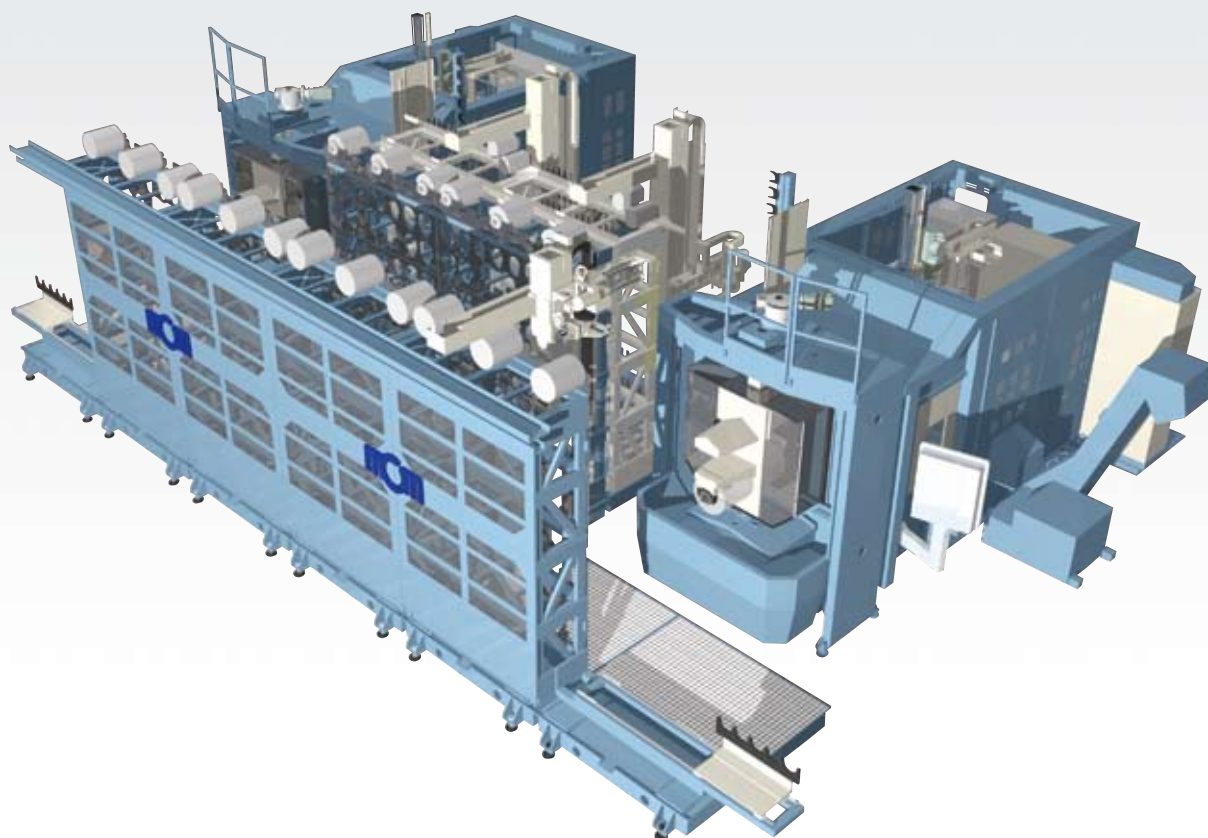

Tempo di cambio utensile	4,5 s
N° utensili Capto C6	315
Rigenerazione utensili + lavaggio + integrità	7 s
Velocità mandrino	14.000 rpm
Tavola girevole continua	5 assi



FLEX MULTITASKING 5 Assi

CARATTERISTICHE TECNICHE

AREA DI LAVORO

Corsa longitudinale X	mm	1.200
Corsa verticale Y	mm	850
Corsa trasversale Z	mm	850
Spinta sugli assi	daN	1.500
Avanzamenti rapidi X e Z	mm/min	75.000
Avanzamenti rapidi Y	mm/min	60.000

GRUPPO MANDRINO

Versione 14.000 rpm CAPTO C6		
Velocità mandrino	rpm	14.000
Potenza continuativa/Potenza max.	kW	40/65
Diametro cuscinetto anteriore	mm	110
Coppia continuativa/Coppia max.	Nm	180/400

CAMBIO UTENSILE CAPTO C6

Capacità di magazzino	n.	315
Lunghezza max. utensile	mm	340
Peso max utensile	kg	8
Tempo di cambio utensile truc.-truc.	s	4,7

PALLET CAPTO C8X

Capacità di magazzino	n.	159
Peso max utensile	kg	60
Dimensioni max movimentabili (Øxlunghezza)	mm	(Ø) 400x(L)350
Tempo cambio pezzo	s	25

MANDRINO-DIVISORE CONTINUO ATTACCO CAPTO C8X

Posizioni		3.600.000
Velocità di rotazione	rpm	2.000

TRASPORTATORE TRUCIOLI

Tipo raschiante

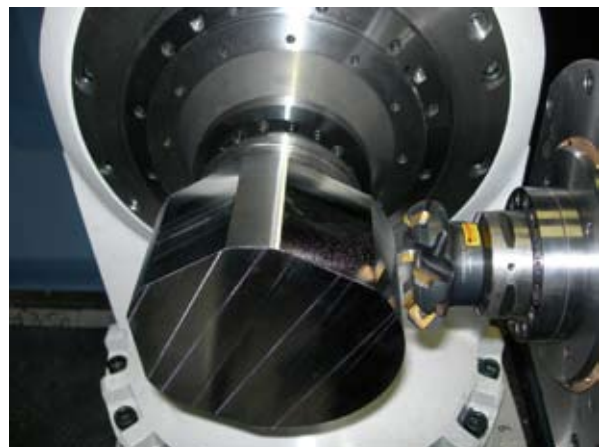
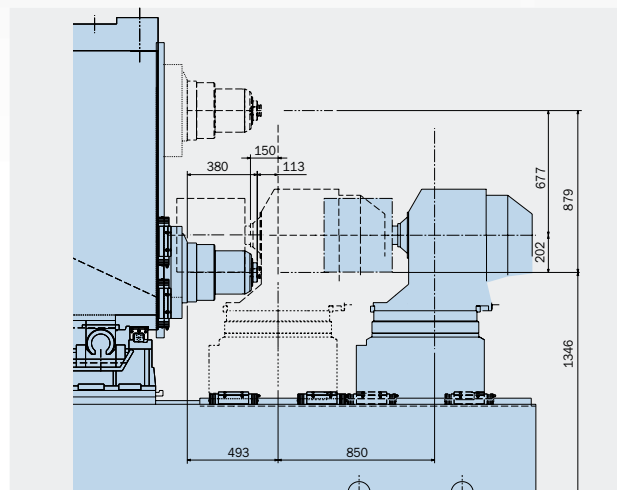
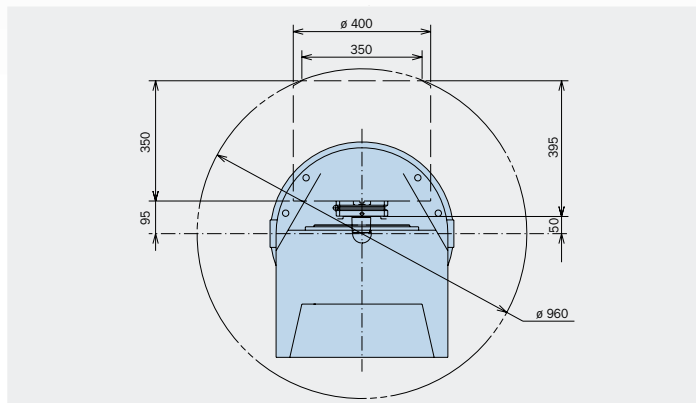

MACHINING CENTERS MANUFACTURING

MCM Spa

I-29020 Vigolzone (PC)
Viale F. e G. Celaschi, 19
Tel. ++39 0523 879901
Fax ++39 0523 879130
E-mail: divcomm@mcmspa.it
http: www.mcmspa.it

MCM FRANCE Sarl

F-91600 Savigny sur Orge
6 Av. du Garigliano
Tel. 01-69-21-21-00
Fax 01-69-24-10-34
E-mail: mcm@mcm-france.com

MCM VERTRIEBS GmbH DEUTSCHLAND

D-65189 Wiesbaden Humboldtstraße, 13
Tel. 0611-372747
Fax 0611-372745
E-mail: rebecchi@t-online.de

MCM CANADA

2311- 29th Ave. LAVAL WEST, QC
H7R 3L4 CANADA
Phone (450) 627 1414
Fax (450) 627 7336
E-mail: astefanoni@sympatico.ca

MCM USA Inc.

34525 Melinz Parkway, Suite 208-C
Eastlake, OH 44095 - U.S.A.
Phone (440) 9181415
Fax (440) 9180776
Toll free 877 MCM 5999